

EN FR IT DE GR

KARAG

bathroom experience...

www.karag.it

FLORA 500
(S-1050)

INSTALLATION MANUAL

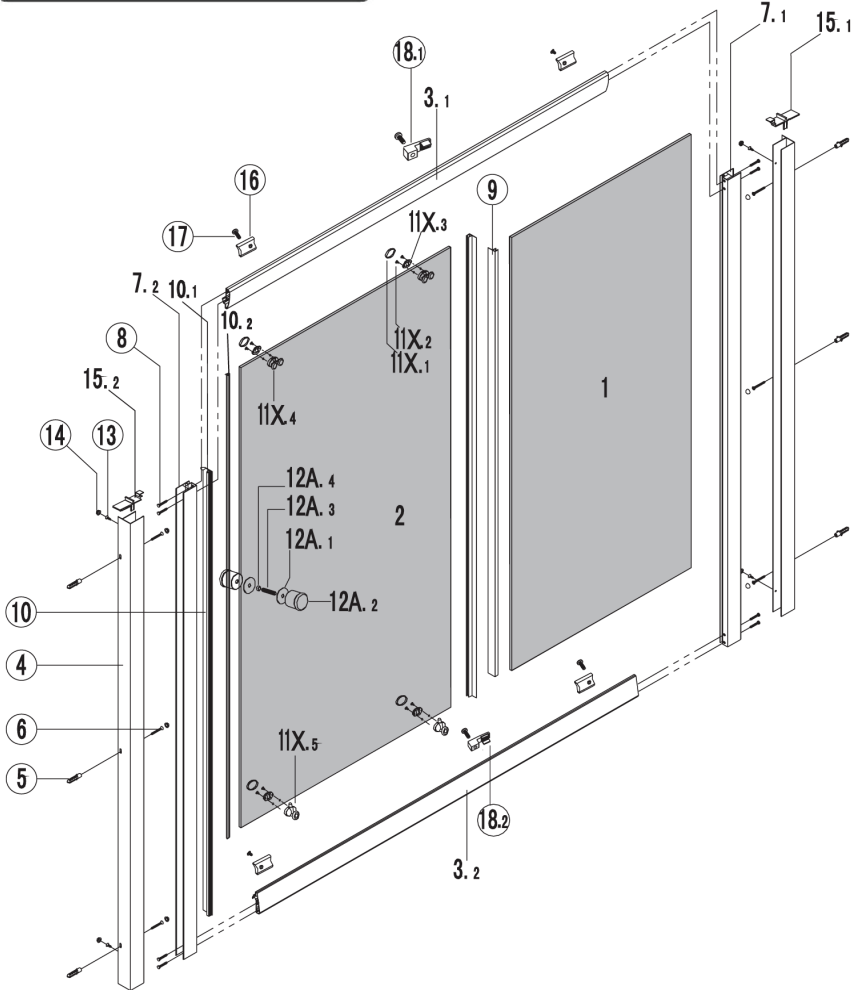
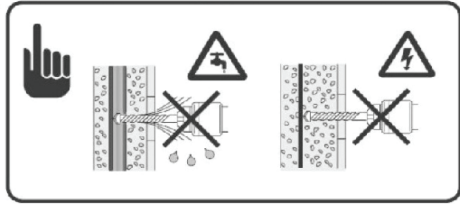
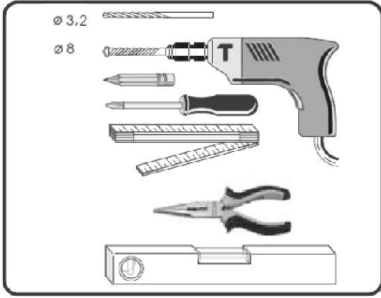

KARAG is not responsible for any spelling or typographical mistakes.

NO.	Designation	Pieces	NO.	Designation	Pieces												
3.1		X1	12	A.1	X4												
1		X1		A.2	X4												
2		X1		A.3	X2												
3.2		X1		A.4	X2												
4		X2		B.1	X1												
5	$\phi 8$	X7		B.2	X1												
6	ST4X35	X7	C.1	C.2	X1												
7.1		X1				C.3	C.4	X4									
7.2		X1							C.5	C.6	X2						
8	ST4X35	X9										C.5	C.6	X2			
9		X2													C.5	C.6	X1
10.1		X1															
10.2		X1	C.5	C.6	X1												
11	X.1	X4				D.1	D.2	X2									
	X.2	X8							D.3	D.4	X2						
	X.3	X4										D.5	D.6	X1			
	X.4	X2													D.5	D.6	X2
	X.5	X2															
Y.1	X8	D.5	D.6	X1													
Y.2	X8				D.5	D.6	X1										
Y.3	X8							D.5	D.6	X1							
Y.4	X8										D.5	D.6	X1				
Y.5	X4													D.5	D.6	X1	
13	ST4X10																X5
14		X11	15.1	15.2													X1
15.1		X1			16	16	X4										
15.2		X1	17	17				X7									
16		X4			18	18	X1										
17	ST4X10	X7	18	18				X1									
18		X1			18	18	X1										
	$\phi 8$	X4															
	$\phi 3.2$	X4															

1.

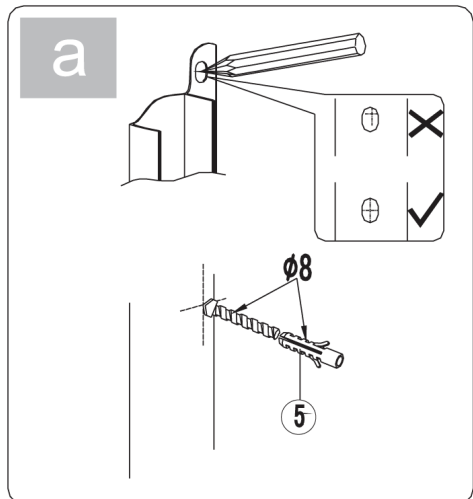
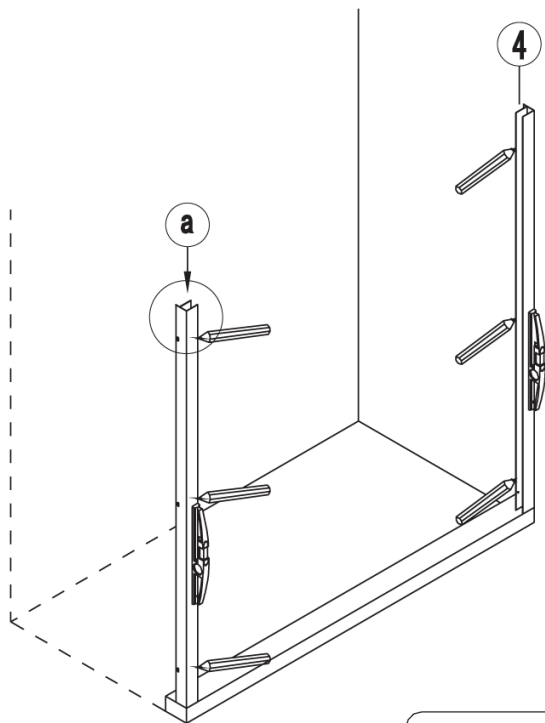

- ▶ Level and screw the vertical wall profiles.
- ▶ Nivelier et serrer les profilés mur verticaux.
- ▶ Livellare ed avvitare i profili muro verticali.
- ▶ Richten sie das Wandprofil aus und schreiben sie es fest.
- ▶ Αλφαδιάστε και βιδώστε τα κάθετα προφίλ τοίχου.

2.

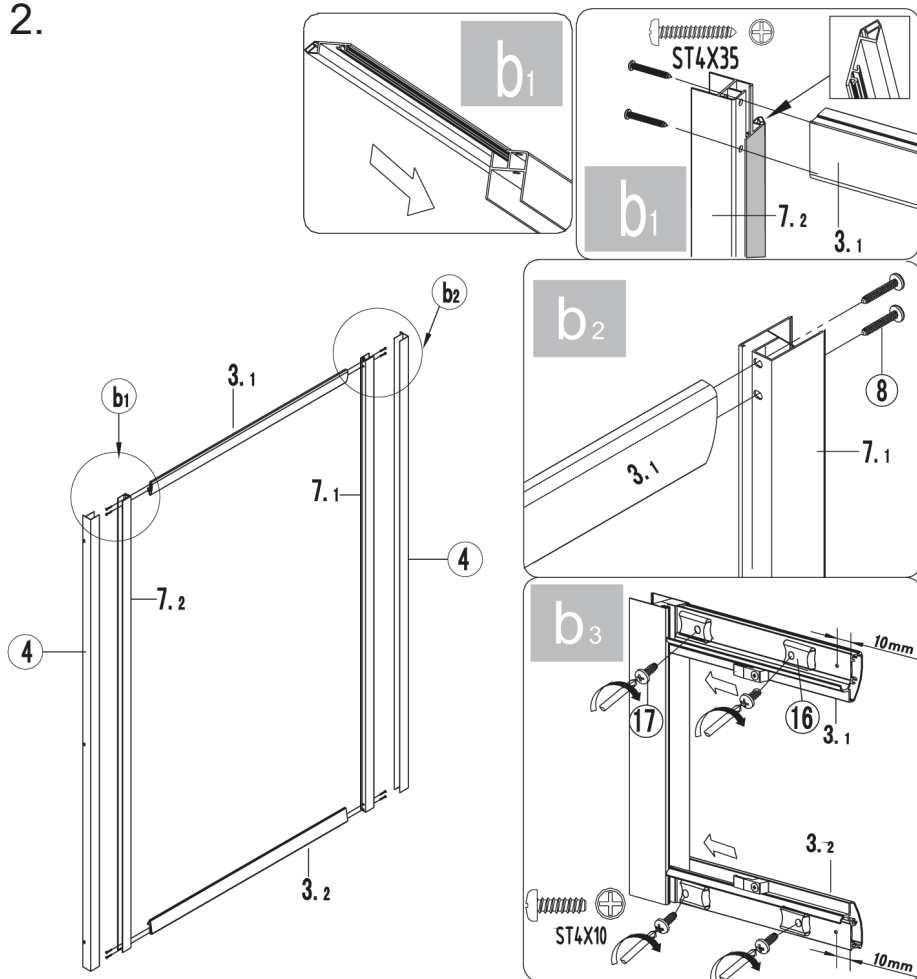

- ▶ Screw the horizontal guides to the vertical profile bearing the special recess for stable crystal in order to set up the metal frame. The recess must be on the inside as on the drawing.
- ▶ Visser les guides horizontaux aux profils verticaux portant la cavité spéciale pour le panneau fixe afin de mettre en place le cadre métallique. La cavité doit être à l'intérieur comme dans le croquis.
- ▶ Avvitare le guide orizzontali sui profili verticali portando l'incavo speciale per il pannello fisso per impostare la struttura in metallo. L'incavo deve essere sul lato interno come nel disegno.
- ▶ Schrauben Sie die horizontalen Führungen zur vertikalen Profil der speziellen Ausparung für einen stabilen Kristall, um den Metallrahmen zu stabilieren. Die Ausparung muss auf der Innenseite sein, wie auf der Zeichnung.
- ▶ Βιδώστε τους οριζόντιους οδηγούς με τα κάθετα προφίλ που φέρουν την ειδική εσοχή για το σταθερό κρύσταλλο, ώστε να στηθεί ο μεταλλικός σκελετός. Η εσοχή πρέπει να είναι από την εσωτερική πλευρά όπως στο σχέδιο.

3.

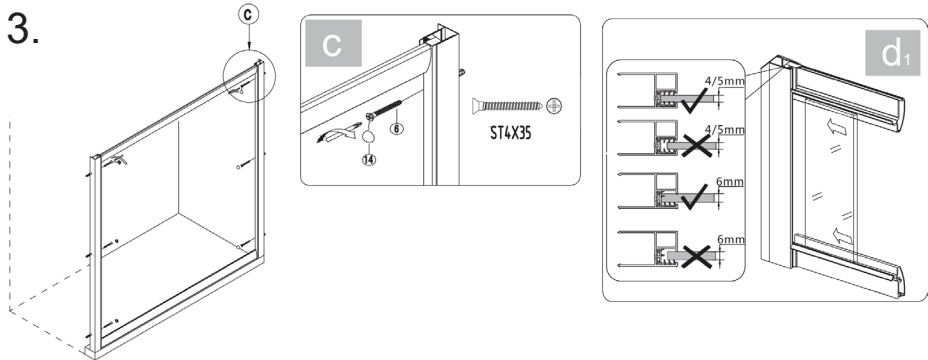

- ▶ Gently place the fixed glass in the duct.
- ▶ Placer doucement le verre fixe dans la cavité spéciale.
- ▶ Posizionare delicatamente il pannello fisso nell' incavo.
- ▶ Setzen Sie Vorsichtig das feste Glas in die dafür vorgesehene Leitung.
- ▶ Τοποθετήστε με προσοχή το σταθερό κρύσταλλο στην ειδική εσοχή.

4.

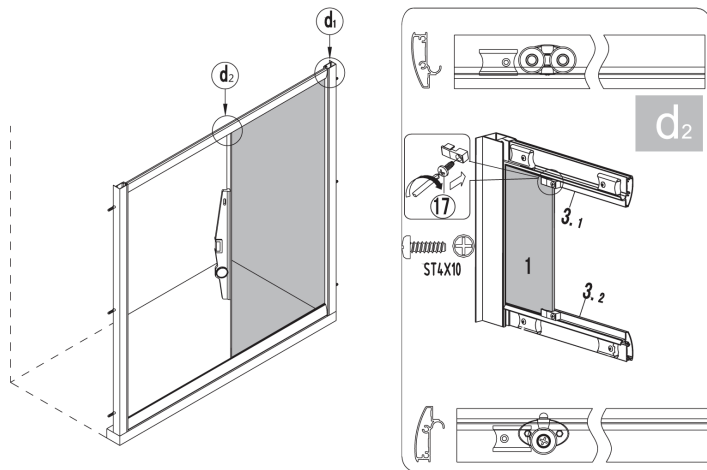

- ▶ Secure by screwing the special clips on the horizontal guide on the one hand, and applying the appropriate rubber wedge on the other in the entire height of the crystal.
- ▶ Fixer-le en vissant les fixations spéciales sur le guide horizontal d'une part, et en apposant le joint de stabilisation approprié sur l'autre dans la totalité de la hauteur du cristal.
- ▶ Fissare avvitando gli attacchi speciali alla guida orizzontale, da un lato, e applicando la guarnizione di stabilizzazione appropriata sull'altro lato in tutta l'altezza del cristallo.
- ▶ Sichern Sie durch die einerseits die speziellen Clips auf der horizontalen Führung schrauben, und in der gesamten Höhe des Kristalls auf der anderen Seite die entsprechenden Gummikeilen anwenden.
- ▶ Σταθεροποιήστε το βιδώνοντας το ειδικό κλιπ στον οριζόντιο οδηγό από τη μια μεριά και εφαρμόζοντας το κατάλληλο λάστιχο σφήνα από την άλλη σε όλο το ύψος του κρυστάλλου.

5.

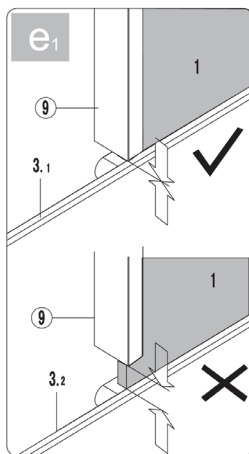
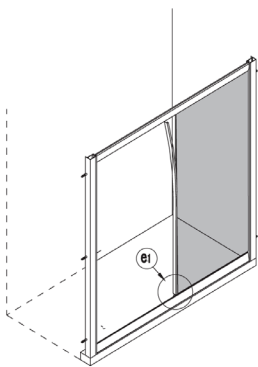

- ▶ Insert the sealing profile by pressing it.
- ▶ Placer appuyant sur le profilé d'étanchéité.
- ▶ Posizionare premendo il profilo di tenuta.

- ▶ Legen Sie das Dichtungsprofil ein durch Drücken.
- ▶ Τοποθετήστε πιέζοντας το προφίλ στεγανοποίησης.

6.

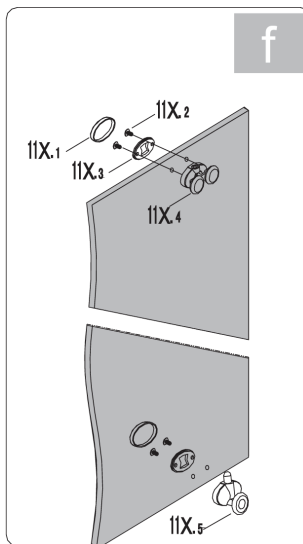
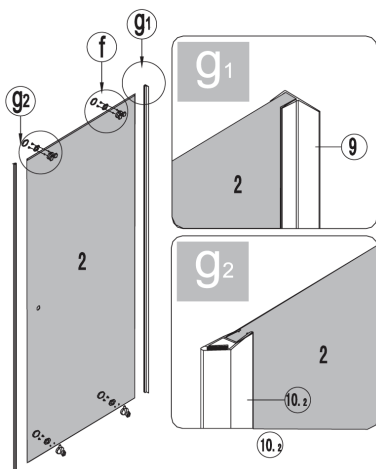

- ▶ Place the sealing rubbers, profiles with magnets, and the rollers.
- ▶ Placer les profilés d'étanchéité, les profils avec des aimants et les rouleaux.
- ▶ Posizionare i profili di tenuta, i profili con magneti e i rulli.
- ▶ Setzen Sie die Dichtungsgummis, die Magneten Profile und die Rollen.
- ▶ Τοποθετήστε τα προφίλ στεγανοποίησης, τα προφίλ με τους μαγνήτες, και τα ράουλα.

7.

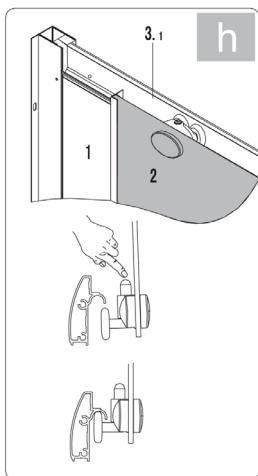
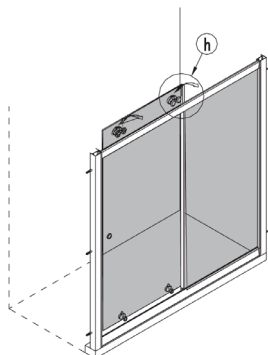

► Hang the doors on the upper guide and lock them by pressing the springs on the lower rollers to apply appropriate and in the lower guide.

► Suspendre le portes sur le guide supérieur et les verrouiller en pressant les ressorts sur les rouleaux inférieurs de façon à appliquer correctement au guide inférieur.

► Appendere la porta sulla guida superiore e bloccare premendo le molle sui rulli inferiori per applicare correttamente la guida inferiore.

► Hängen Sie die Türen auf der oberen Führung ein und verriegeln Sie diese durch Drücken der Federn auf den unteren Rollen um die untere Führung angemessen zu übernehmen.

► Κρεμαστέ τις πόρτες στον επάνω οδηγό και ασφαλίστε τες πιέζοντας τα ελατήρια στα κάτω ράουλα ώστε να εφαρμόσουν κατάλληλα και στον κάτω οδηγό.

8.

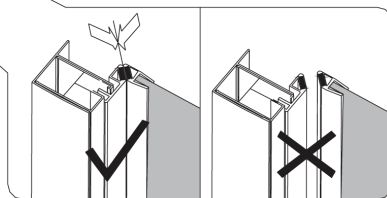
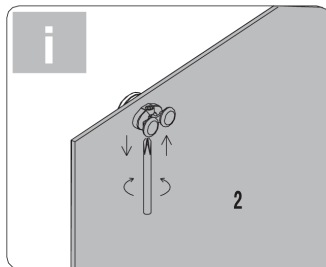
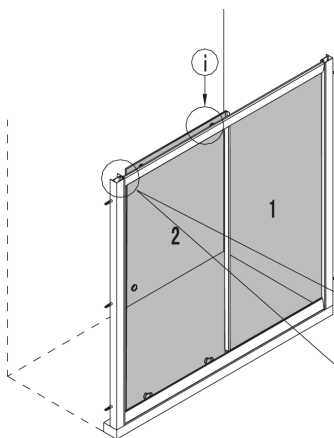

► Adjust a door with the screws located on the upper rollers.

► Régler le porte par les vis des rouleaux supérieurs.

► Regolare la porta dalle viti sui rulli superiori.

► Stellen Sie die Tür mit den Schrauben an den oberen Rollen angeordnet.

► Ρυθμίστε την πόρτα από τις βίδες που βρίσκονται στα επάνω ράουλα.

9.

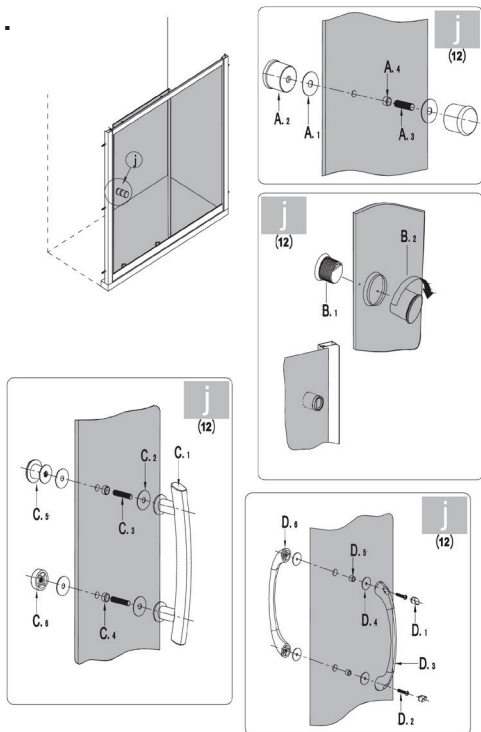

- ▶ Place the handles on the doors.
- ▶ Placer les poignées sur les portes.
- ▶ Posizionare le maniglie sulle ante.
- ▶ Setzen Sie die Griffe an den Türen.
- ▶ Τοποθετήστε τα χερούλια στις πόρτες.

10.

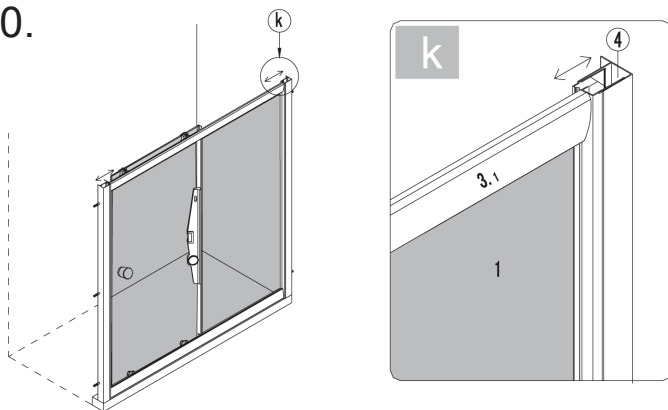

- ▶ The wall profiles allow adjustment 30mm from each side.
- ▶ Les profils de mur permettent un réglage de 30 mm de chaque côté.
- ▶ I profili muro consentono 30 millimetri di regolazione da ogni lato.
- ▶ Die Wandprofile ermöglichen die Anpassung von 30 mm von jeder Seite.
- ▶ Τα προφίλ τοίχου παρέχουν τη δυνατότητα ρύθμισης 30mm από κάθε πλευρά.

11.

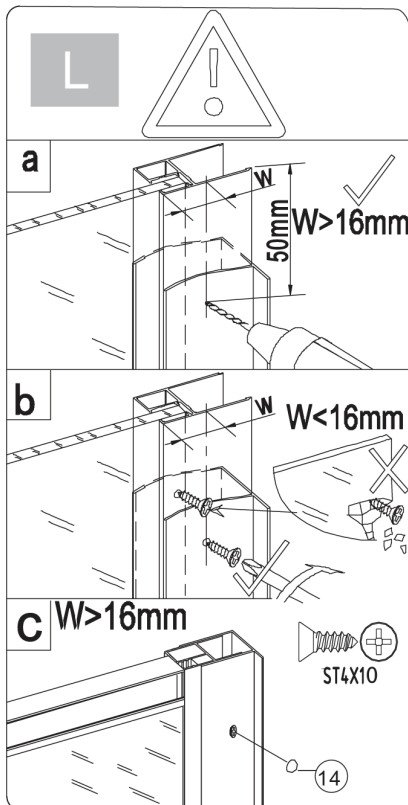
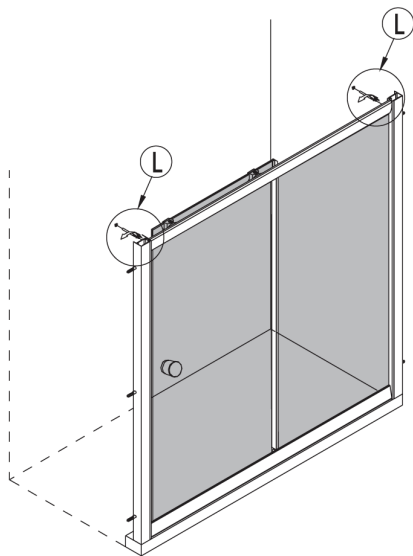

- ▶ Level and fix with suitable screws the frame with the vertical wall profile.
- ▶ Niveller et stabiliser le cadre par des vis appropriées aux profils mur verticaux.
- ▶ Livellare e stabilizzare il telaio a mezzo di viti sui profili muro verticali.
- ▶ Setzen Sie Vorsichtig das feste Glas in die dafür vorgesehene Leitung.
- ▶ Αλφαδιάστε και σταθεροποιήστε με τις κατάλληλες βίδες τον σκελετό με τα κάθετα προφίλ τοίχου.

12.

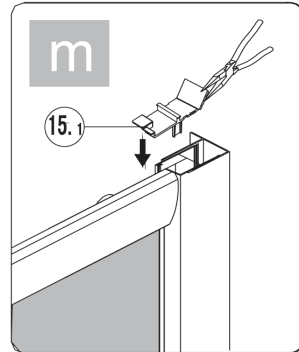
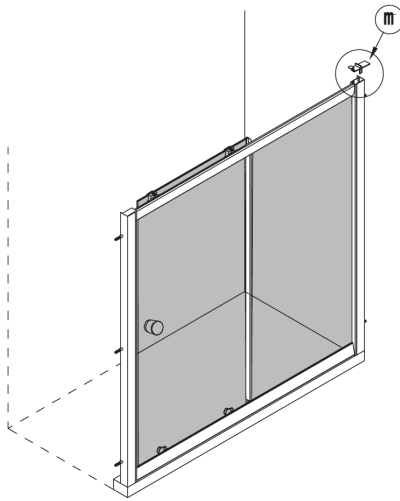



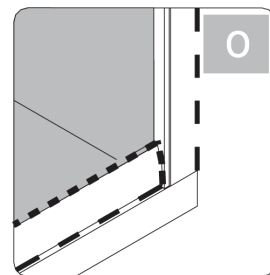
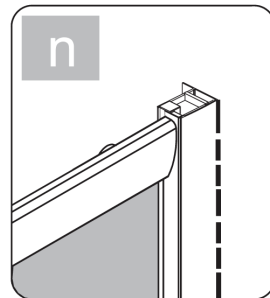
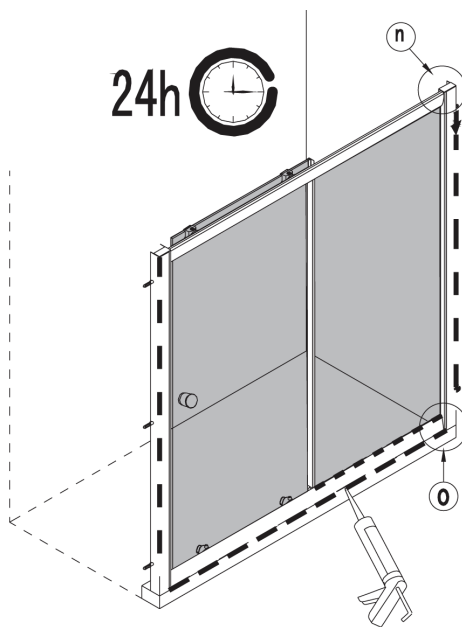

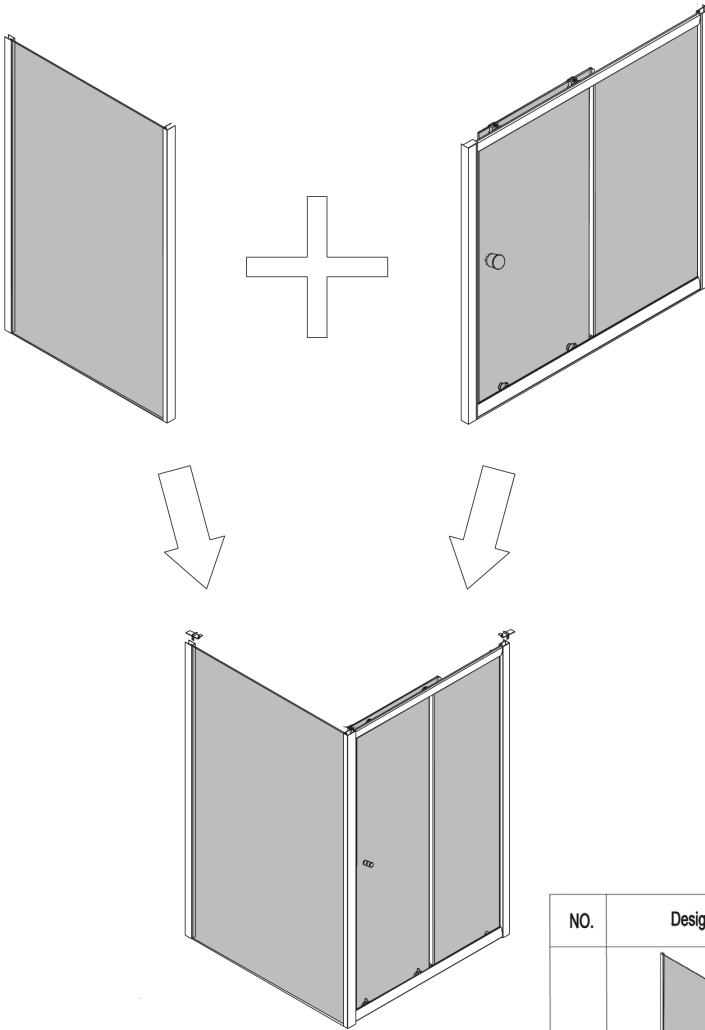

13.



- ▶ Apply silicone around.
- ▶ Appliquer autour de la silicone.
- ▶ Applicare silicone attorno.
- ▶ Silikon einsetzen.
- ▶ Εφαρμόστε σιλικόνη περιμετρικά.



NO.	Designation	Pieces
p1		X1
p2	  ST4X12	X2+1
p3		X2+1
p4		X1
		X1

1.

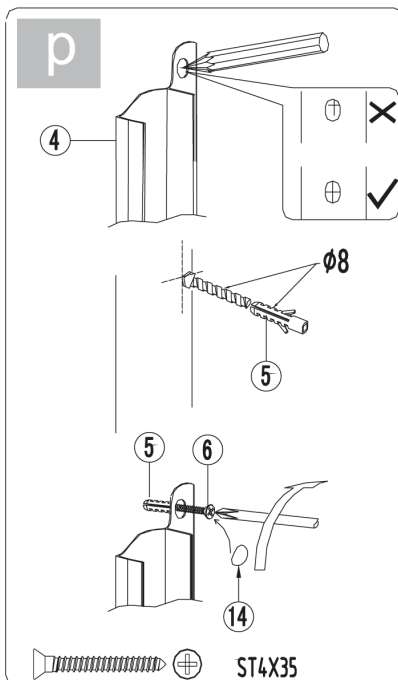
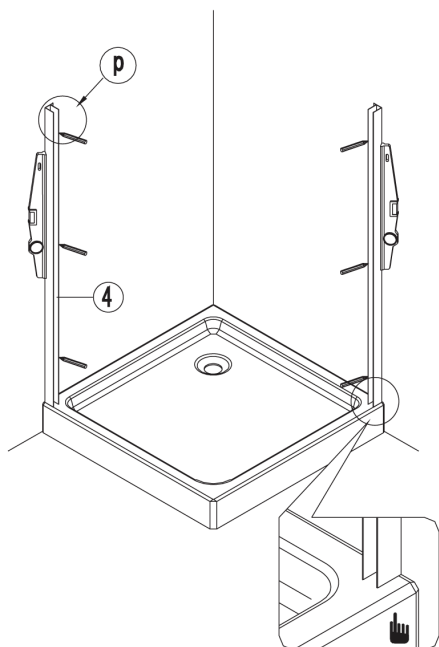

- ▶ Level and screw the vertical wall profiles.
- ▶ Nivelier et serrer les profilés mur verticaux.
- ▶ Livellare ed avvitare i profili muro verticali.
- ▶ Richten sie das Wandprofil aus und schreiben sie es fest.
- ▶ Αλφαδιάστε και βιδώστε τα κάθετα προφίλ τοίχου.

2.

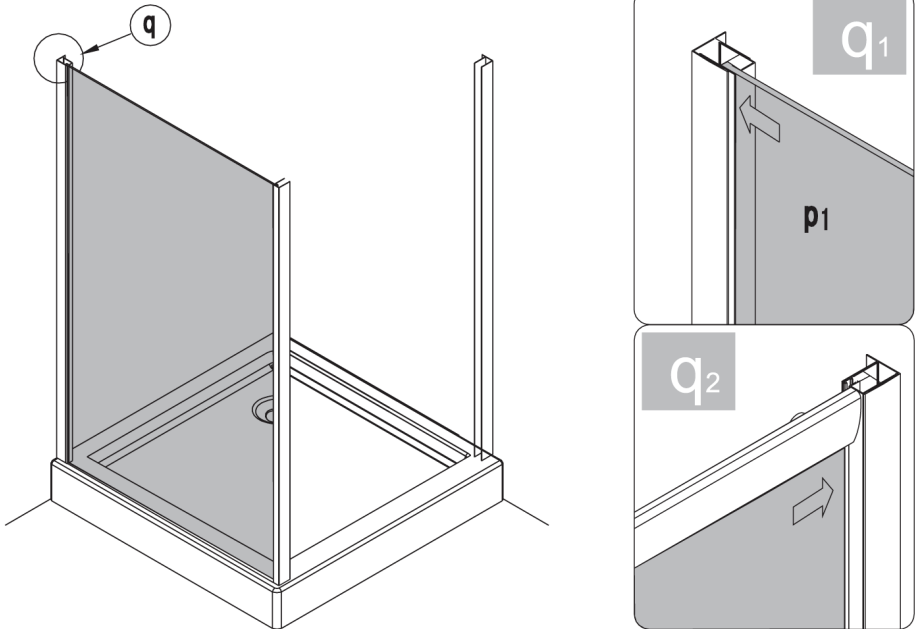

- ▶ Gently place the fixed glass in the duct.
- ▶ Placer doucement le verre fixe dans la cavité speciale.
- ▶ Posizionare delicatamente il pannello fisso nell' incavo.
- ▶ Setzen Sie Vorsichtig das feste Glas in die dafür vorgesehene Leitung.
- ▶ Τοποθετήστε με προσοχή το σταθερό κρύσταλλο στην ειδική εσοχή.

3.

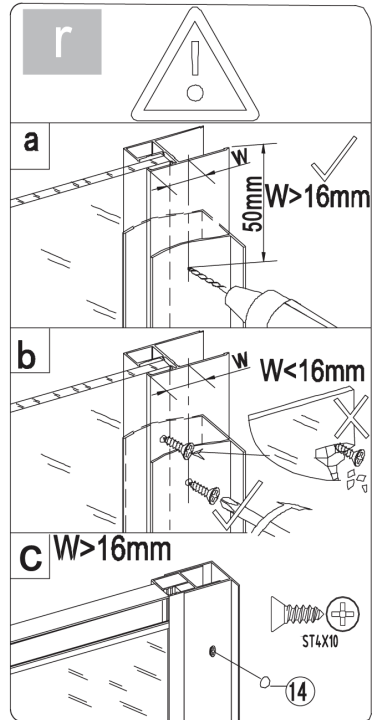
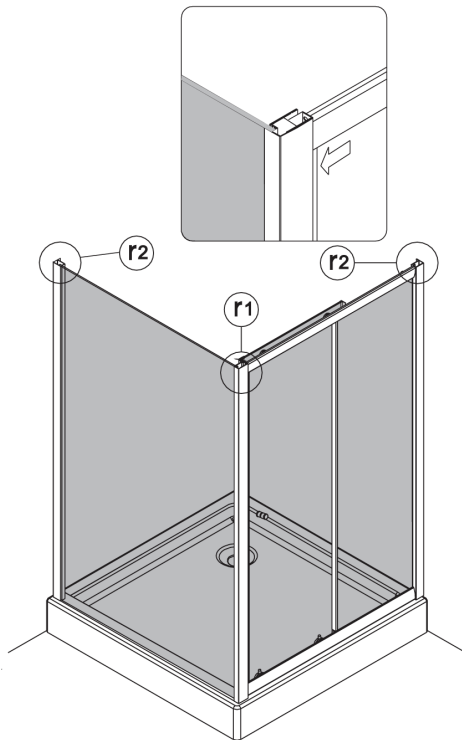

- ▶ Level and fix with suitable screws the frame with the vertical wall profile.
- ▶ Niveller et stabiliser le cadre par des vis appropriées aux profils mur verticaux.
- ▶ Livellare e stabilizzare il telaio a mezzo di viti sui profili muro verticali.
- ▶ Setzen Sie Waagerecht die geeigneten Schrauben der Rahmen mit dem vertikalen Wandprofil.
- ▶ Αλφαδιάστε και σταθεροποιήστε με τις κατάλληλες βίδες τον σκελετό με τα κάθετα προφίλ τοίχου.

4.

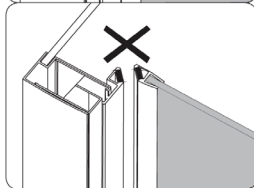
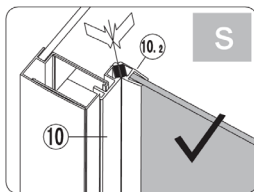
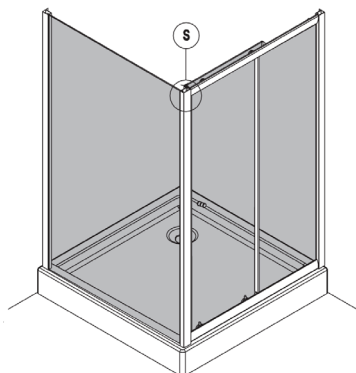

5.

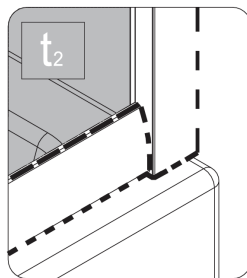
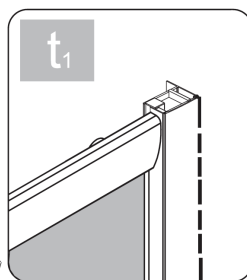
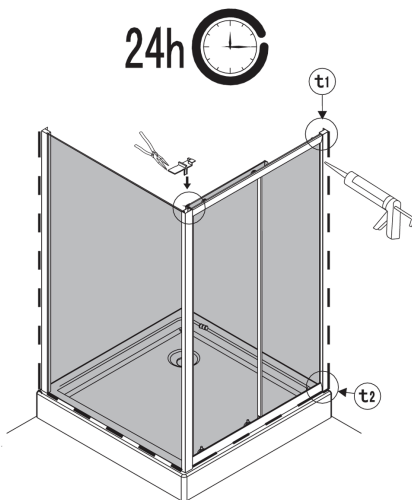

- ▶ Apply silicone around.
- ▶ Appliquer autour de la silicone.
- ▶ Applicare silicone attorno.
- ▶ Silikon einsetzen.
- ▶ Εφαρμόστε σιλικόνη περιμετρικά.

Copyright © 2016 KARAG Italia Srl



FLORA 500
S-1050

KARAG Italia Srl
7, 25 Aprile street
41 042 FIORANO MODENESE (MO)
ITALIA
(+30) 0039 0536 921230
info@karag.it / www.karag.it